

Autonomous Hovering of a Fixed-Wing Micro Air Vehicle

William E. Green and Paul Y. Oh*
Drexel Autonomous Systems Lab
Drexel University, Philadelphia, PA
[william.e.green,paul.yu.oh]@drexel.edu

Abstract

Recently, there is a need to acquire intelligence in hostile or dangerous environments such as caves, forests, or urban areas. Rather than risking human life, backpackable, bird-sized aircraft, equipped with a wireless camera, can be rapidly deployed to gather reconnaissance in such environments. However, they first must be designed to fly in tight, cluttered terrain. This paper discusses an additional flight modality for a fixed-wing aircraft, enabling it to supplement existing endurance superiority with hovering capabilities. An inertial measurement sensor and an onboard processing and control unit, used to achieve autonomous hovering, are also described. This is, to the best of our knowledge, the first documented success of hovering a fixed-wing Micro Air Vehicle autonomously.

1 Introduction

More often, homeland security, search-and-rescue, and disaster mitigation efforts have taken place in unforeseen environments which include caves, tunnels, forests, cities, and even inside urban structures. Performing various tasks, such as surveillance, reconnaissance, bomb damage assessment, or evacuating the injured within an unfamiliar territory is dangerous and also requires a large, diverse task force. However, unmanned robotic vehicles could assist in such missions by providing situational awareness without risking the lives of soldiers, first responders or other personnel [6] [2].

Backpackable, bird-sized aircraft or Micro Air Vehicles (MAVs) can be rapidly deployed to provide an “over-the-hill” or “around-the-corner” perspective

*This material is based upon work supported by the National Science Foundation under Grant No. 0347430. Any opinions, findings, and conclusions or recommendations expressed in this material are those of the author(s) and do not necessarily reflect the views of the National Science Foundation. Pages: <http://www.pages.drexel.edu/~weg22/research.html>



Figure 1: A fixed-wing MAV transitions to hovering mode to gently maneuver itself through a small opening of an urban structure. *Inset:* once inside, the onboard wireless camera is used to capture and transmit surveillance images.

from a remote location. Moreover, a fixed-wing platform capable of hovering would allow potentially long hover and stare modes while maintaining long flight times and a dash capability to avoid enemy fire [3]. The hovering mode would also allow flight in caves, tunnels, and other tight, enclosed labyrinths (see Figure 1).

Designing such a vehicle requires a large thrust-to-weight ratio ($T/W > 1$). This enables the aircraft to overpower its way through the stall regime and into a hovering position (i.e. the longitudinal axis of the fuselage is vertical). Once in the vertical orientation, the large T/W ratio enables it to hover by balancing the weight of the aircraft with the thrust from the motor. However, the aircraft is unstable in this configuration and requires an expert human pilot to constantly manipulate the aircraft’s yaw and pitch control surfaces in order to sustain a hover. With full autonomous operation in mind, taking the hu-

man out of the loop during this difficult maneuver is a logical first step. An onboard control system and inertial measurement unit (IMU) were used to sustain the hover. To the best of our knowledge, this is the first work in the open literature which documents autonomous hovering of a fixed-wing aircraft ¹.

This paper illustrates the usefulness of a hovering, fixed-wing aircraft for flight in cluttered terrain. Section 2 discusses the platform characteristics and weight breakdown of the most recent prototype. Section 3 describes the demanding task of manually hovering a fixed-wing MAV while Section 4 details the attitude sensor and controller used to achieve the maneuver autonomously. Section 5 presents the experimental results and the paper concludes with sections on future work and conclusions.

2 Platform Design

To be capable of surveilling inside a cave or tunnel, a hovering platform is required. Hovering platforms such as helicopters and ducted fans [5] are not rapidly maneuverable and also lack the endurance advantages of fixed-wing aircraft. Lighter-than-air platforms like blimps [8] are typically too large for flight in cluttered terrain because buoyancy is proportional to size. A fixed-wing platform can be designed to be both small and rapidly maneuverable. Furthermore, incorporating a high thrust-to-weight ratio into the design would enable the aircraft to perform a maneuver known as prop-hanging. Adopted from the radio-controlled (R/C) community, prop-hanging enables a fixed-wing aircraft to hover by balancing the weight with the thrust generated by the propeller.

In order to transition into and sustain a hover, a thrust-to-weight ratio greater than one is required. With a weight estimate of 600 grams as shown in Table 1, a brushless motor was selected which can generate more than 1000 grams of thrust (i.e. a $T/W = 1.67$). Another design factor is that the aircraft must be controlled with limited airflow (i.e. prop wash) over the control surfaces once in the hovering position. As a result, the control surface areas of the vertical and horizontal tails and wing must also be increased. The net result is that a small drag force can be used to regulate rotation about all three axes. Figure 2 shows our prototype in its hovering orientation.

¹This claim assumes that the fixed-wing genre excludes tiltrotor aircraft such as Boeing’s Eagle Eye UAV and platforms that can stop their rotor in mid-flight to act as a fixed-wing like Boeing’s Canard Rotor/Wing (CRW).

Part Description	Weight (grams)
Carbon Fiber Airframe	324
Motor, Gearbox, and Prop	85
Servos (4)	36
Lithium-Poly Battery	85
Speed Controller and Receiver	25
Inertial Measurement Unit	26
Onboard Control System	18
Total	599

Table 1: MAV weight distribution.

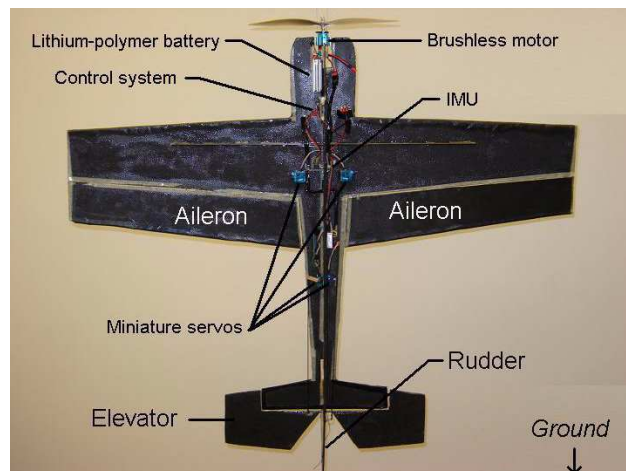

Figure 2: The fixed-wing prototype in its hovering orientation.

3 Hovering a Fixed-Wing MAV

To enter the hovering flight mode, the MAV must first transition through the critical high angle-of-attack regime. During this phase, there exists an angle-of-attack, α , for which the wings are no longer a contributing factor to the lift component (i.e. stall). To achieve the maneuver, the aircraft has to leverage its momentum and essentially overpower its way through the stall regime (see Figure 3). The aircraft’s high thrust-to-weight ratio helps to preserve momentum through this transition, thus avoiding stall. This maneuver occurs in under two seconds as seen by the captured flight data in Figure 4.

After a successful transition to the secondary flight mode, sustaining a hover under manual control is very challenging. The maneuver requires an expert human pilot to continuously manipulate four channels of a radio-controlled transmitter (see Figure 5). Assuming the aircraft is in, or close to, the hovering attitude (i.e. fuselage is vertical), the formidable process



Figure 3: Our MAV prototype with a 90 cm wingspan transitions from cruise flight (left) through the stall regime (middle) and into a hovering position (right) at an altitude of 10 meters (zoomed photos).

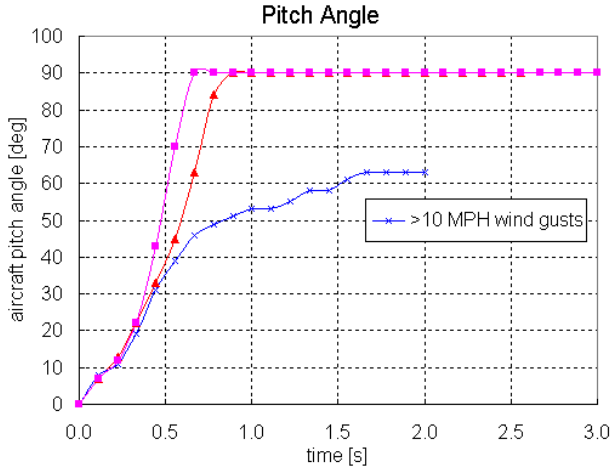

Figure 4: Actual flight data which shows the MAV pitch angle as it transitions from cruise to hover flight. Also, it can be seen that when hovering into wind, some forward thrust is required (e.g. pitch angle of 60 degrees) to remain stationary.

is as follows: (i) increase/decrease the throttle if the plane begins to lose/gain altitude, (ii) apply left/right rudder deflection if the plane begins to yaw to the left/right, (iii) administer up/down elevator if the aircraft starts to pitch forward/back, and (iv) counter the moment created by the motor torque by deflecting the ailerons. The four steps above must be done in parallel, however, once a throttle position is found which balances the weight of the aircraft, the pilot focuses more on the remaining three channels. Furthermore, the torque-roll created by the high-powered brushless motor (which is relatively constant due to the throttle being fixed), is about the vertical axis and thus, will not significantly disturb the aircraft from its hovering attitude. As such, the two most demanding tasks in manual hovering include keeping the



Figure 5: Manual hovering demands control of all four transmitter channels. *Inset*: simultaneous picture of aircraft in a hover.

aircraft's yaw and pitch orientation constant through rudder and elevator deflection, respectively.

Figure 6 shows a free-body diagram of the forces of flight acting on the aircraft during a hover. Summing the forces in the vertical direction yields

$$\begin{aligned} \Sigma F_{z_{elevator}} = 0 \Rightarrow T \cos(\theta - 90) - D \cos(\theta - 90) & \quad (1) \\ -W - F_E \sin \delta_E \cos(\theta - 90) = 0 & \end{aligned}$$

$$\begin{aligned} \Sigma F_{z_{rudder}} \Rightarrow T \cos \psi - D \cos \psi - W - F_R \sin \delta_R \cos \psi & \quad (2) \\ = 0 & \end{aligned}$$

where F_E and F_R are the elevator and rudder restoring forces, respectively, and are functions of the drag force, D , and control surface deflection angle, δ . It can be seen from (1) and (2), that when the aircraft is in a perfect hover (i.e. $\theta = 90$, $\psi = 0 \Rightarrow \delta_E = \delta_R = 0$), the thrust must equal both the weight and drag forces.

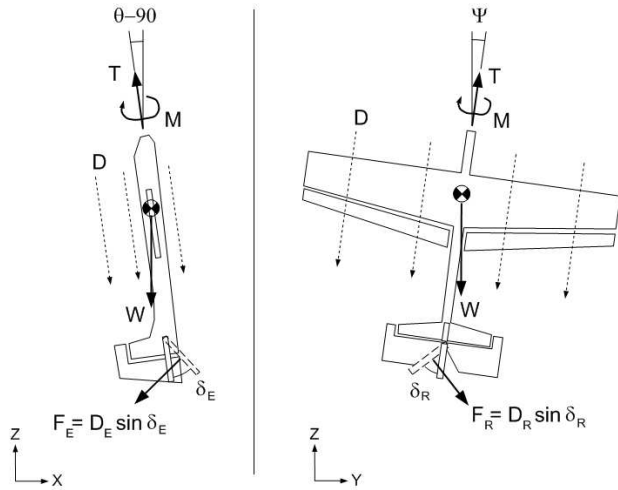

Figure 6: When in a hovering attitude, the elevator and rudder control surfaces are used to regulate the pitch and yaw angles, respectively.

4 Sensors and Control for Automation

In order to make the secondary flight mode autonomous, the aircraft's attitude needs to be measured and fed back to an onboard control system. Microstrain's 3DM-GX1 inertial measurement unit (IMU) consists of three orthogonal accelerometers and gyros which are interpreted to output orientation at a rate of more than 100 Hz. The sensor's small size (65 mm x 90 mm x 25 mm) and weight (30 grams out of protective casing) enable it to be easily mounted to the MAV platform. The IMU interfaces with a control circuit which includes a PIC16F87 microcontroller and a RS232 converter chip to communicate serially with the sensor.

During cruise flight, the control system acts as an autopilot by controlling the rudder, elevator and ailerons to maintain steady level flight. However, the MAV pitch angle will approach ninety degrees during the transition from cruise to hover flight. As such, conventional Euler angle notation will yield erroneous data due to gimbal lock. To avoid this phenomenon, an alternative method must be employed. Microstrain's IMU is also able to output the orientation data in quaternion form (see Figure 7). This $[4 \times 1]$ vector,

$$\begin{aligned} q_0 &= \cos(\theta/2) \\ q_1 &= e_1 \sin(\theta/2) \\ q_2 &= e_2 \sin(\theta/2) \\ q_3 &= e_3 \sin(\theta/2) \end{aligned}$$

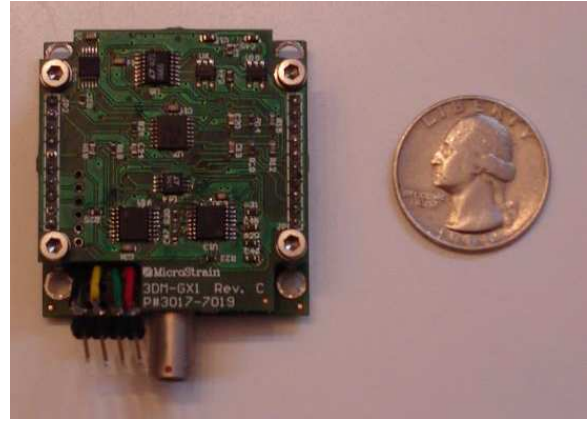

Figure 7: Microstrain's 30 gram IMU sensor was used to acquire attitude information at 100 Hz.

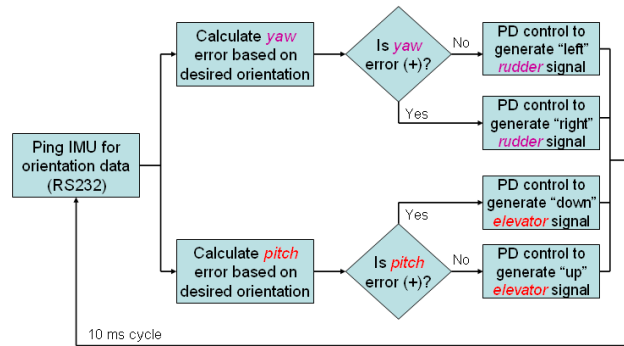

Figure 8: Flow chart describing the autonomous hovering code.

where q_1 , q_2 , and q_3 define the axis of rotation and q_0 is the angle of rotation about that axis, is fed into the onboard control system at 100 Hz. After comparing the current orientation to the desired orientation ($q_0=0.707$, $q_1=0$, $q_2=0.707j$, $q_3=0$) to calculate the error, proportional-derivative (PD) control is implemented to yield the corresponding pulse-width modulated (PWM) elevator and rudder servo commands (see Figure 8). Countering the effects of the motor torque through aileron deflection was initially ignored because a panoramic view of the flying area was desired. Furthermore, the throttle is controlled manually to allow for altitude adjustment. This is beneficial because surveillance at different heights (e.g. various floors, different perspectives, etc.) can be obtained.



Figure 9: MAV performing a *hands-off* autonomous hover in and urban structure. *Inset*: a shot from the MAV’s bellycam is shown.

5 Experiments

The first autonomous hovering experiments were conducted inside an urban structure, with limited flying space, (i.e. $3 \times 3 \text{ m}^2$ area), to demonstrate the usefulness of the secondary flight mode. This was followed by an experiment to contrast the differences in stability between manual and computer-controlled hovering. Finally, the autonomous transition from cruise to hover flight was evaluated.

5.1 Autonomous Hovering

The aircraft was released in near-hovering orientation (i.e. the fuselage is close to vertical) and manually given enough throttle to balance the aircraft weight. The controls are simultaneously handed off to the onboard control system. Initial experiments demonstrated that the MAV was able to successfully hover in “hands-off” mode for 35 seconds before slowly drifting out of the designated flying area (see Figure 9). It should be noted that the aileron control surfaces remained in the neutral position (i.e. no deflection) throughout the flight. This was to purposefully allow torque roll so the MAV’s bellycam could acquire panoramic footage of its surroundings.

5.2 Manual vs. Autonomous Hovering

The last experiment was performed to visually contrast hovering under both manual and autonomous control. The metrics used were (i) duration of the hover before losing control and (ii) stability of the aircraft while in hovering mode. The human pilot was initially given control of the aircraft and was instructed to fly around the gymnasium in cruise con-

figuration. Then, after manually making the transition from cruise to hover flight, the pilot attempted to hover the aircraft for as long as possible. The video stills² show the pilot struggling to keep the fuselage vertical, but is able to keep the aircraft positioned over a small area (see top of Figure 10). The human pilot was able to sustain a hover for several minutes, but was unable to stabilize the aircraft in the vertical position.

Next, the pilot was instructed to again fly in cruise configuration and manually make the transition from cruise to hover flight. However, instead of trying to hover the aircraft manually, the pilot flicked a switch on the transmitter which enabled the onboard controller. This time, the aircraft is fixed in a vertical position and is able to hover for minutes before draining the battery (see bottom of Figure 10).

6 Future Work

The ultimate goal of the authors is to develop a back-packable, fully autonomous Micro Air Vehicle to fly in caves, tunnels, urban areas. Designing a fixed-wing platform that can autonomously hover was a major milestone towards this. However, there are many other challenges that must be addressed for full autonomous flight in these environments.

The most critical is to avoid collisions when in the hovering flight mode. Collision avoidance involves first detecting the obstacle and then planning a path around it. The authors plan to leverage their previous work on optic flow for obstacle detection [4]. Planning paths around obstacles requires accurate control of the MAV’s position. The torque-rolling effect makes this extremely difficult. This can be eliminated through the use of counter-rotating propellers or by increasing the aileron surface area. Also, during a hover, the aircraft tends to drift when in the presence of wind. Optic flow can also be used for gust stabilization [7] [1]. In order to hover in one position, the optic flow on the ground must be zeroed out.

Finally, the transition from the primary to secondary flight modes must also be autonomous. This is the more imminent task and must be implemented through the use of quaternions. This is more difficult than autonomous hovering because of the fragile tran-

²The video sequence shows three images extracted once per second for a period of three seconds. With the plane rotating at a rate of 0.25 revolutions per second, this is enough to show two quarter rotations.



Figure 10: A human pilot hovers a fixed-wing aircraft in a small gymnasium and struggles to sustain a hover (top). Under autonomous control, the same aircraft is able to sustain a hover for more than 90 seconds (bottom).

sition through the high angle-of-attack stall regime.

7 Conclusions

Patrolling caves, tunnels and other labyrinths demands a vehicle that can hover. Furthermore, other MAV missions, such as gathering reconnaissance around a mountain or over a hill a few miles ahead, requires high endurance traits. Designing an aircraft for such missions demanded a vehicle that was compact, maneuverable, capable of carrying a payload and most importantly, capable of hovering. The successful development of a fixed-wing MAV with hovering capabilities offers both high endurance characteristics along with the benefits of stationary flight. Furthermore, these unconventional flying environments are usually enclosed and thus degrade GPS signals. Therefore, autonomous flight requires that all processing be done onboard the aircraft. The 15 gram processing and control unit reads attitude information from the IMU at a 100 Hz rate, and implements PD control on the rudder and elevator control surfaces to achieve autonomous hovering. This research is the first to demonstrate autonomous hovering of a fixed-wing aircraft.

References

[1] Barrows, G., “Mixed-Mode VLSI Optic Flow Sensors for Micro Air Vehicles”, *Ph.D. Dissertation*, University of Maryland, College Park, MD, Dec. 1999.

- [2] Blitch, J., “World Trade Center Search-and-Rescue Robots”, Plenary Session *IEEE Int Conf Robotics and Automation*, Washington D.C., May 2002.
- [3] Green, W.E., Oh, P.Y., “A MAV That Flies Like an Airplane and Hovers Like a Helicopter”, *IEEE/RSJ International Conference on Advanced Intelligent Mechatronics*, pp. 699-704, Monterey, CA, July 2005.
- [4] Green, W.E., Oh, P.Y., Barrows, G., “Flying Insect Inspired Vision for Autonomous Aerial Robot Maneuvers in Near-Earth Environments”, *IEEE International Conference of Robotics and Automation*, pp. 2347-2352, New Orleans, LA, April 2004.
- [5] Hamel, T.; Mahony, R., Chriette, A., “Visual Servo Trajectory Tracking for a Four Rotor VTOL Aerial Vehicle”, *IEEE International Conference on Robotics and Automation (ICRA)*, Washington, D.C., pp. 2781-2786, 2002.
- [6] Murphy, R., et al, “Mobility and sensing demands in USAR”, *IEEE Industrial Electronics Conference (IECON)*, V1, pp. 138-142, 2000.
- [7] Srinivasan, M.V., Chahl, J.S., Weber, K., Venkatesh, S., Nagle, M.G., Zhang, S.W., Robot Navigation Inspired By Principles of Insect Vision in *Field and Service Robotics*, A. Zelinsky (ed), Springer Verlag Berlin, NY 12-16.
- [8] Zhang, H., Ostrowski, J.P., “Visual Servoing With Dynamics: Control of an Unmanned Blimp”, *IEEE International Conference on Robotics and Automation (ICRA)*, Detroit, pp. 618-623, 1999.